

# AUTOMATIC CONDENSATE DRAIN – AOK50B

## DESCRIPTION

AOK50B has been developed for fully automatic discharging of condensate or any other non-aggressive fluid from compressed air<sup>(1)</sup> system. The unit can be installed as external drain on any application specified below. Condensate accumulates in the aluminium reservoir and when the level is high enough condensate is being discharged from the system. Direct acting valve is operated by precise level controlled floater which assures reliable and efficient operation. Thanks to light aluminium housing AOK50B for ease mounting and is also suitable for heavy duty applications. On front side AOK50B is also equipped with separate manual drain or venting.



## APPLICATIONS<sup>(2)</sup>

- Air Compressor (piston or screw)
- After-cooler
- Cyclone condensate separator
- Pressure vessel/Air tank
- Air dryer
- Air filter

<sup>(1)</sup>For any other technical gas please contact us or your local dealer

<sup>(2)</sup>AOK50B can be used in variety of applications. For applications not listed please contact us or your local dealer.

## TECHNICAL SPECIFICATION

Operating temperature	1,5 - 65 °C	35 - 149 °F
Operating pressure	8 - 50 barg	101 - 725 psi
Normally open	< 1barg	
Normally closed	> 8barg	
Minimum recommended operating pressure	10barg	145 psi
Operating media	Condensate (air, water, oil); Non-aggressive	
Nominal discharge capacity	145 l/h (at 50barg)	/
Discharge orifice cross cection	1,8mm	0,0708 inch
Inlet connection	G ½" (NPT on request)	
Outlet connection	G ½" (NPT on request)	
Reservoir volume	0,45 l	
Weight	2,8 kg	
Valve type	Servo, Normally open	

## MATERIALS

Housing material	Anodized aluminum
Screws, Other components	Stainless steel 1.4404, A4
Floater	Polyamide (PA6)
Sealing	NBR, FPM

### CALCULATION OF CAPACITY

For rough calculation of discharge capacity at certain pressure use following equation:

$$Q = 20,5\sqrt{\Delta p} \quad \text{Example: if operating at 7barg; } Q = 20,5\sqrt{35} = 121,3 \text{ l/h}$$

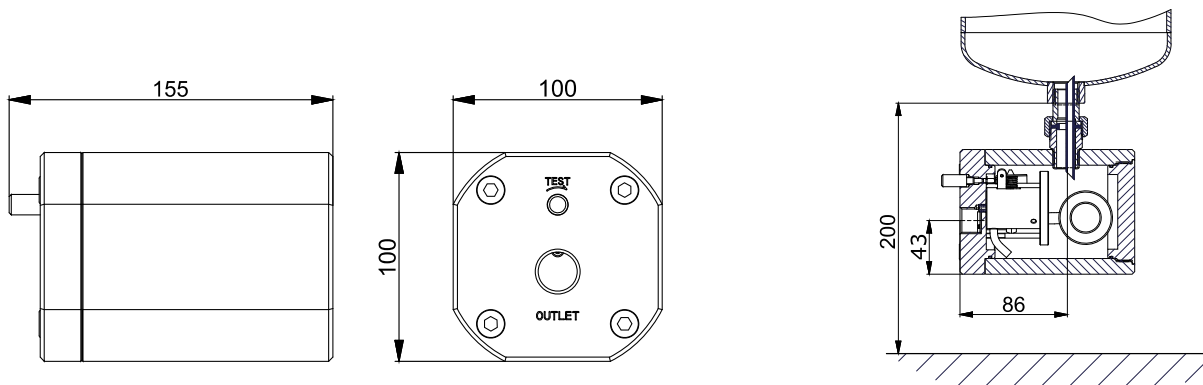

### PRESSURE EQUIPMENT DIRECTIVE PED 97/23/CE (Fluid group 2)

Product type

AOK50B

Category, module

Not required

### MAINTENANCE

Once per year make a visual check of the drain and make sure there is no visual damage or leakage. Clean interior of the reservoir regularly. Intervals of cleaning depend on contamination of condensate. Replace the sealings if necessary.

### RECCOMENDATIONS

- We recommend the use of ball valve between pressure vessel and inlet connection.
- We recommend the use of strainer element between pressure vessel and inlet connection.
- We recommend the use of nipple with venting tube to avoid generation of air bubbles. Nipple is screwed in inlet connection.

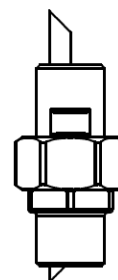

Condensate discharged from compressed air system contains significant amounts of lubricant oil. We strongly recommend connecting AOK50B to oil water separator. In most countries content of oil in waste water is regulated by law.

### INFORMATION IN THIS DOCUMENT IS SUBJECT TO CHANGE WITHOUT NOTICE

	<p>Our quality management system is certified by BUREAU VERITAS in conformity with ISO 9001:2008 Reg. number: 200285</p>	
--	--	--