

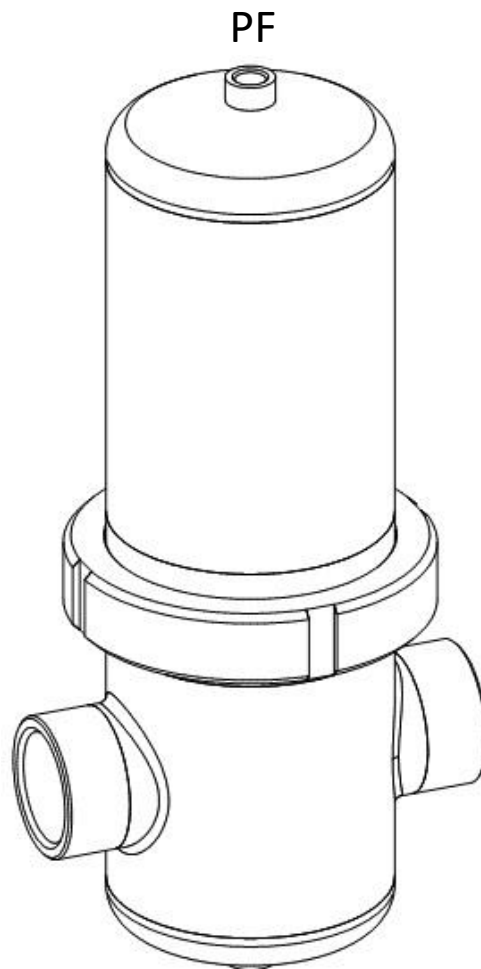

# Installation and operating manual



Please read the following instructions carefully before installing filter into service. Trouble-free and safe operating of the filter can only be guaranteed if recommendations and conditions stated in this manual are respected.



## Table of content

1. Components.....	4
2. Technical data .....	5
2.1 Technical specification.....	5
2.2 MATERIALS.....	5
2.3 Pressure equipment directive PED 2014/68/EU (Fluid group 2).....	5
2.4 Pressure equipment directive PED 2014/68/EU (Fluid group 1) <sup>(5)</sup> .....	6
3. Safety instructions .....	6
3.1 Notes and warning signs.....	6
3.2 Hazard classes.....	6
3.3 Structure of the warnings.....	7
3.4 Safety measures .....	7
4. Intended use .....	8
5. Warranty exclusion / Improper use .....	8
6. Storage information.....	8
7. Installation .....	9
7.1 Installation instructions .....	9
8. Operating .....	11
9. Maintenance .....	11
9.1 Instruction for regular checks.....	12
9.2 Service.....	13
9.3 Disposing of filter.....	13
9.4 Replace the filter element .....	14

**Table of illustrations**

Illustration 1: Disassembled filter housing..... 4  
Illustration 2: Dimensions of filter housing..... 5  
Illustration 3: depressurize system ..... 10  
Illustration 4: Correct connection ..... 10  
Illustration 5: Connect pipe ..... 10  
Illustration 6: Lubricate O ring ..... 10  
Illustration 7: Insert filter element..... 10  
Illustration 8: Mount filter bowl / nut..... 10  
Illustration 9: Tighten nut..... 10  
Illustration 10: Correct installation ..... 10  
Illustration 11: Open valves..... 10  
Illustration 12: Correct flow direction ..... 10  
Illustration 13: Depressurize system ..... 14  
Illustration 14: Replace filter element ..... 14  
Illustration 15: Lubricate O ring ..... 14  
Illustration 16: Insert filter element..... 14  
Illustration 17: Mount filter bowl / nut..... 14  
Illustration 18: Tighten nut..... 14  
Illustration 19: Open valves..... 14



**1. Components**

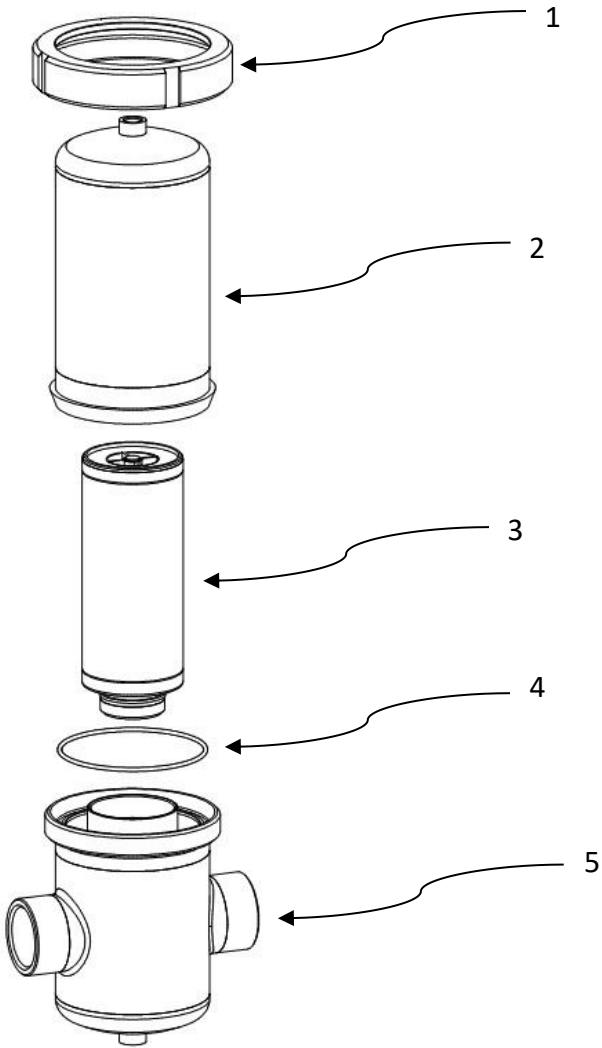

Part	
1	Clamp
2	Filter bowl
3	Filter element
4	O-ring
5	Filter head

Illustration 1: Disassembled filter housing

## 2. Technical data

### 2.1 Technical specification

FILTER HOUSING G	PIPE SIZE-D	FILTER ELEMENT	OPERATING PRESSURE	FLOW CAPACITY		DIMENSIONS [mm]				VOLUM E [l]	WEIGH T [kg]
				[Nm <sup>3</sup> /h ]	[scfm]	A	B	C	E		
PF 005	1/4"	0310	14	75	44	206	12	76,1	1/4"	0,70	1,8
PF 007	3/8"	0410	14	105	62	236	12	76,1	1/4"	0,80	2,0
PF 010	1/2"	0420	14	150	88	239	12	76,1	1/4"	0,84	2,1
PF 018	3/4"	0520	14	225	132	263	12	76,1	1/4"	0,95	2,2
PF 030	1"	0525	14	315	185	280	13	88,9	1/4"	1,4	3,0
PF 047	1 1/4"	0725	14	420	247	343	15	88,9	1/4"	1,8	3,4
PF 070	1 1/2"	0730	14	600	353	376	18	114	1/4"	3,4	4,6
PF 094	2"	1030	14	900	530	445	18	114	1/4"	4,1	5,2
PF 150	2"	1530	14	1260	742	572	18	114	1/4"	5,3	6,0
PF 175	2 1/2"	2030	14	1680	989	736	22	139	1/4"	10,2	9,6
PF 200	3"	3030	14	2400	1.413	979	22	139	1/4"	14	13,7
PF 240	3"	3050	14	3600	2.119	1041	25	168	1/4"	21	18,5
PF 450	DN100	3x 2030	10	5040	2.966	981	41	219	1"	34	56
PF 600	DN100	3x 3030	10	6720	3.955	1240	41	219	1"	43	60
PF 900	DN150	4x 3030	10	9600	5.650	1311	48	273	1"	72	90
PF 1200	DN150	6x 3030	10	13440	7.910	1330	54	323	1"	102	112
PF 1800	DN200	8x 3030	10	17280	10.17	1496	66	406	1"	181	201
PF 2000	DN200	10x 3030	10	21120	12.43	1496	66	406	1"	181	202

Flow capacity at 7 bar(g), 20°C

Standard is BSP pipe connection, other pipe connection on request.

### Operating conditions

Operating temperature -20 - 150 °C -4 - 302 °F

Operating pressure 0 - 14 bar(g) 0 - 203 psi

\*Actual operating temperature depend on sealing material and type of filter element

### Correction factors

To calculate the correct capacity of a given filter based on actual operating conditions, multiply the nominal flow capacity by the appropriate correction factor(s).

CORRECTED CAPACITY = NOMINAL FLOW CAPACITY x C<sub>OP</sub>

### Correction factors acc. to operating pressure

[bar]	2	3	4	5	6	7	8	9	10	11	12	13	14	15	16
[psi]	29	44	58	72	87	100	115	130	145	160	174	189	203	218	232
C <sub>OP</sub>	0,38	0,5	0,63	0,75	0,88	1	1,13	1,25	1,38	1,50	1,63	1,75	1,88	2,00	2,13

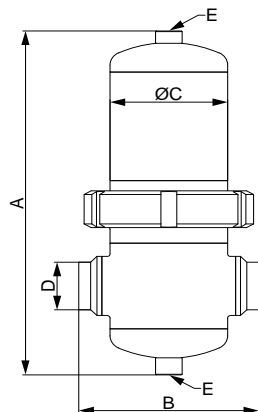

Illustration 2: Dimensions of filter housing

### 2.2 MATERIALS

Housing material Stainless steel (quality 1.4404; on request 1.4301)

Sealing EPDM (Optional FKM or SILICONE)

Housing finishes Polished down to grade Ra1.6 (externally)

Lubricant (Optional Shell cassida grease RLS 2)

### 2.3 Pressure equipment directive PED 2014/68/EU (Fluid group 2)

PF 005 - PF 070	Article 4.3
PF 094 - PF 200	Category 1, Module A
PF 240 - PF 900	Category 2, Module H
PF 1200-PF 2000	Category 3, Module H

## 2.4 Pressure equipment directive PED 2014/68/EU (Fluid group 1)<sup>(5)</sup>

PF 005 – PF 047	Article 4.3
PF 070	Category 1, Module A
PF 094 – PF 200	Category 2, Module H
PF 240 – PF 600	Category 3, Module H
PF 1200 – PF 2000	Category 4, Module H1

<sup>(5)</sup> Fluid group must be specified in the order, if not standard fluid group 2 is selected.

There is Technical datasheet available. For additional technical specification, contact manufacturer.

## 3. Safety instructions

### 3.1 Notes and warning signs

#### Respect the following symbols and instructions!



**MANDATORY:** Instructions must be read by persons operating with the filters!

The instruction manual supplied and all other applicable instructions, regulations must be read and understood by operating personnel before using the filters.



**MANDATORY:** Protectors for eyes must be worn!

Protectors for eyes must be worn when working with the filters.



**MANDATORY:** Protectors for hands must be worn!

Protectors for hands must be worn when working with the filters.



**WARNING:** Operating with high pressure!

Depressurize the filter before carrying out any work on the filter.



**CAUTION** due to the hot touch surfaces!

Hot surfaces, do not touch!

Danger of burning by touching a filter housing.

### 3.2 Hazard classes

Important instructions regarding personal protection and safe operation are indicated in the manual in distinct hazard classes. The hazard classes explain how states or individual steps of an operation sequence are dangerous and can cause damage.

Hazard class	Description
DANGER	Indicates an immediate or imminent danger. Failure to observe this warning may result in death or serious injuries.
WARNING	Indicates a potentially dangerous situation. Failure to observe this warning may result in death or serious injuries.
CAUTION	Indicates a potentially dangerous situation. Failure to observe this warning may result in minor injuries.
NOTICE	Indicates a potentially dangerous situation. Failure to observe this warning may result in material damage.

### 3.3 Structure of the warnings

The warnings describe the type and source of danger, the consequences of not heeding these warnings, and measures to be taken to avert danger. A warning is always structured according to the following pattern:

#### **WARNING**

##### **Type and source of danger.**

Consequences of not heeding the warning.

- Measures for averting the danger.

### 3.4 Safety measures

The relevant safety at work and accident prevention regulations, plus operating instructions, shall apply for operating the filter.

The filter has been constructed in accordance with the generally recognized rules of engineering. It complies with the requirements of directive 2014/68/EU concerning pressure equipment.

Ensure that installation complies with local laws for operation and routine testing of pressure equipment at the place of installation.

The operator/user of the filter should make himself familiar with the function, installation and start-up of the unit. All the safety information is always intended to ensure your personal safety.

- Do not exceed max. operating pressure and operating temperature range (see data label).
- Ensure that not using the medium, which could attack the materials.
- All installation and maintenance work on the filter may only be carried out by trained and experienced specialists.
- It is forbidden to carry out any kind of work (modification or repair) on the filter and piping, including welding and constructional changes, etc.
- Use the device for an appropriate purpose only.
- Do not open the filter housing until you make sure that it is not pressurized any more.
- Ensure that use the product in a technically perfect condition and in the intended manner, which takes into account safety-related considerations, danger-related considerations and the operating instructions.
- In addition to the manual, follow and advise the generally applicable binding regulations for accident prevention and for environmental protection.
- When exchanging the filter keep in mind that it might have operating temperature.
- Always wear safety goggles and gloves when working on the filter.

#### 4. Intended use

PF process filter housings are intended for applications in process industry, where the risk for corrosion of compressed air system components is very high. This appliance must be used only for the purpose for which it was specifically designed. All other uses are to be considered incorrect.

Intended use includes:

- Compliance with these manual
- Compliance with all applicable legal regulations

Specifically:

- The air purified with this filter is not intended for human breathing without proper additional equipment.

The information on the product label must be observed. Non-observance of the data given there is regarded as improper use.

The manufacturer will under no circumstances be responsible for any damage resulting from improper, incorrect or unreasonable use.

#### 5. Warranty exclusion / Improper use

Any use apart from the intended use mentioned above is considered to be not intended. The manufacturer/supplier can assume no liability for damage resulting from this type of usage. The user alone bears the risk of this.

The guarantee shall be void if:

- The operating instructions were not followed with respect to initial commissioning and maintenance.
- The filter was not operated properly and appropriately.
- The filter was operated when it was clearly defective.
- If unauthorized or unqualified persons work with or on the filter.
- When operating without safety equipment or with incorrect or non-functional safety equipment.
- Non-original spare parts or replacement parts were used.
- The unit was not operated within the permissible technical parameters.
- Unauthorized constructional changes were made to the filter or if parts of the filter that may not be opened were dismantled.
- The filter and filter elements did not be store indoors and in a dry place.
- If part of the filter was removed, when the filter was still pressurized!  
Depressurize the filter before carrying out any work on the filter.
- If operator damaged O-ring / gasket during replacement the filter elements and do not replaced it.

#### 6. Storage information

The following guidelines must be considered to ensure proper operation:

- Store the filter and filter elements indoors in a dry place.
- Store them in original packaging until they are used.





## 7. Installation

### WARNING

#### **Danger due to wrong installation!**

Improper installation can result in personal and material damage.

- Ensure that the filter is installed by qualified personal having skills and experience with pneumatics.

### WARNING

#### **Danger due to the release of a critical gas!**

The release of a critical (Fluid group 1) gas from the network can constitute a considerable risk for man and environment.

- Depressurize the filter and network before carrying out any work on the filter.

### WARNING

#### **Warning due to exceed a maximum permissible temperature and pressure!**

Exceed a maximum permissible temperature and pressure can result in personal and material damage.

- Respect the permissible value of working temperatures and pressures. The permissible working temperatures and pressures for ad-on parts and filter elements are given under Technical data for those ad-ons. The maximum temperature and pressure for the assembled system are the lowest of any individual part.

### 7.1 Installation instructions

1. Depressurize the system before carrying out the installation work.
2. When connecting a pipe to the filter, take care that no dirt or foreign bodies or liquids enter the filter, the direction of flow IN – OUT is adhered to.
3. Install the filter vertically and in such a way that the condensate exit is below.
4. Connect inlet and outline pipe to the filter, see instruction on picture 4 and 5 on page 10.
5. The filter must be installed with a minimum distance to the ground in relation to the height of the filter elements used and plus 50mm allowance, for easy replacement the filter elements. (The height of the filter elements is specified in the data-sheet of the filter elements).
6. Install the pressure equipment in such a way that it is accessible for the possibly inspections and can be viewed from all sides.
7. A pressure gauge, which shows the operational pressure, must be installed in the pressure system, respectively in the pipeline.
8. Install a manual or automatic condensate drain device. For installation instructions please refer to the manual of the device.
9. Install suitable safety devices, such as safety valves, rupture discs or safety related measurement control and regulation devices or ensure that the permissible operating value limits are not exceeded.
10. Ensure that the filter housing, the system connections and accessory outlets are leak tight.

11. Ensure that the installation of the filter housing be made by using an appropriate mounting bracket to avoid excessive loads on the piping.
12. Ensure that the filter is not subject to vibrations that could cause fatigue fractures.
13. Ensure that filter is not be subjected to mechanical stresses.

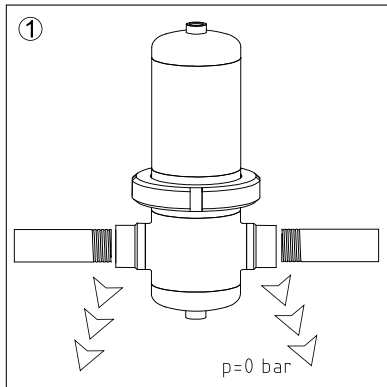

Illustration 3: depressurize system

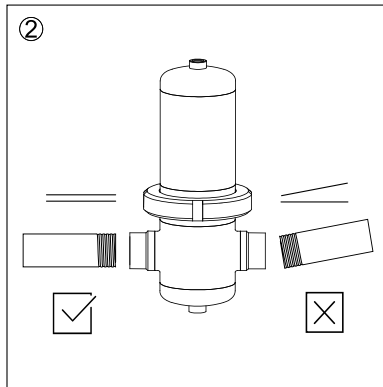

Illustration 4: Correct connection

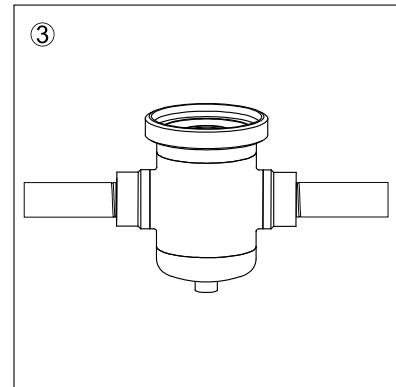

Illustration 5: Connect pipe

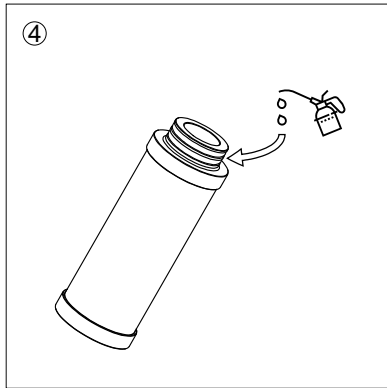

Illustration 6: Lubricate O ring

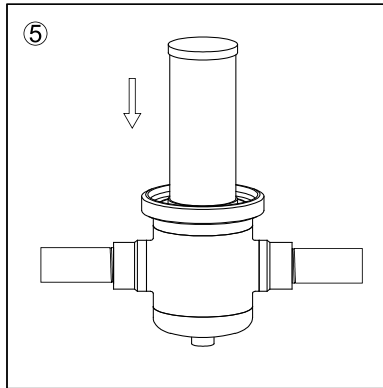

Illustration 7: Insert filter element

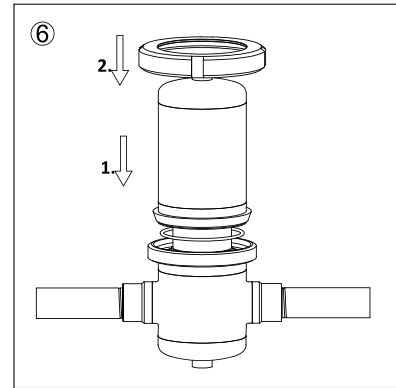

Illustration 8: Mount filter bowl / nut

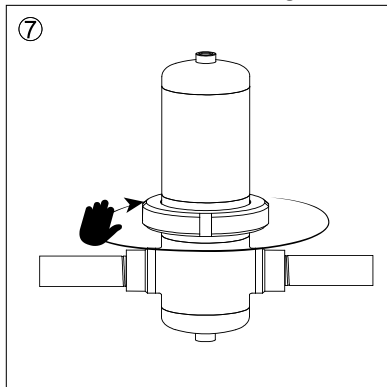

Illustration 9: Tighten nut

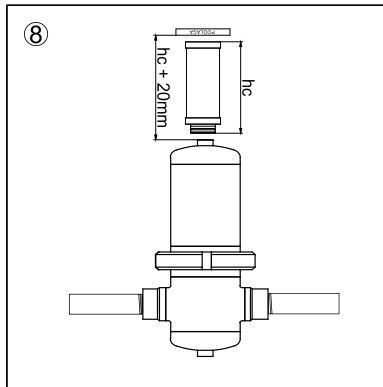

Illustration 10: Correct installation

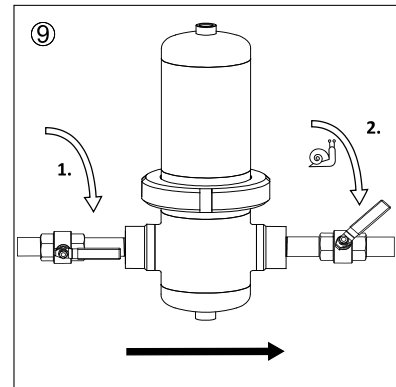

Illustration 11: Open valves

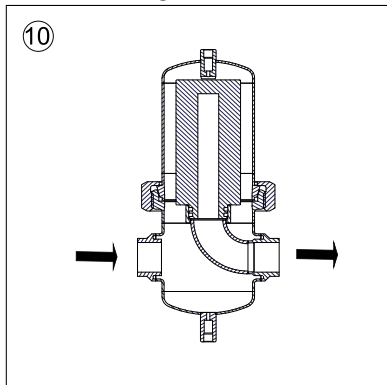

Illustration 12: Correct flow direction

## 8. Operating

### **WARNING**

#### **Warning to operate with high pressure and temperature!**

Eventual over-pressure and over-temperature could be dangerous and hazardous to the operator and the equipment.

- Operations should be performed only by qualified personnel and is responsible for ensuring that the filter never operates at a pressure and temperature exceeding the nominal values.

Operate the filter according to the instructions below and in the given sequence.

1. Before any work ensure that the filter housing are tightly closed.
2. Ensure that work with a permissible pressure! If too much air pressure is applied to the filter, you may burst the filter elements. In technical data of filter element is stated a maximum allowed pressure of filter element, if this value of pressure is achieved, you must to replace the filter elements. Check the pressure in system!
3. Open the valve on the inlet side of the strainer.
4. When the valve on the inlet side is full open, slowly open the valve on the outlet side of the filter. The filter is now in service.

### **NOTICE**

#### **Risk of material damaged!**

Inadequate condensate drain intervals lead to the flooding of the filter and damage the downstream pressure devices.

- The draining intervals depend upon the operating conditions and must be determined individually.
5. Drain condensate regularly.

### **NOTICE**

#### **Risk of inefficient operation of filter element.**

As the filter element removes dirt from the air, the accumulated dirt causes a resistance to flow. As a result, the pressure will rise and the flow will decrease.

- As soon as pressure grows for value (**see the value about differential pressure in a technical data given attached to the filter elements**) above the starting pressure or when the flow decreases below the desired rate, replace the filter element.
6. Control regularly the operating parameters.

## 9. Maintenance

### **WARNING**

#### **Warning due to a sudden release of pressure!**

High pressure could be dangerous and hazardous to the operator.

- Depressurize the filter before carrying out any work on the filter.
- Never remove any parts of the filter, when the filter is still pressurized!

**⚠ WARNING**

**Danger due to the release of a critical gas!**

The release of a critical (Fluid group 1) gas from the network can constitute a considerable risk for man and environment.

- Depressurize the filter before carrying out any work on the filter.

Therefore heed the following before working on filters for critical gases:

- Flush the pipe section in question with inert gas,
- Observe the notes on hazardous substances for the used gas ready,
- Take appropriate protection measures.

**⚠ CAUTION**

**Caution due to the hot touch surfaces!**

High temperature could be dangerous and hazardous to the operator.

The gaseous fluid flowing through the filter could have a temperature up to 150°C/302°F.

- **Do not touch hot surfaces!** Wear safety gloves if applicable.

**NOTICE**

**Risk of material damaged!**

Internal corrosion can seriously reduce the safety of installation!

- Check it during changing the filter element.

Filter elements are subject to wear. To maintain system efficiency, optimal performance and best air quality, these rules of proper maintenance should be followed.

**9.1 Instruction for regular checks**

1. If installed, weekly check the pressure drop indicator to ensure the filter element is not saturated, and pressure drop is within acceptable limits.
2. If installed, ensure a trouble-free operation of the condensate drain. Check At least once a week if condensate drain operates regularly.
3. Replace filter elements at least once per year or when pressure drop reaches value (see product data sheet for filter element).
4. PI and PB filter element can be cleaned with ultrasonic bath or with back flushing. Intervals of cleaning depend on application. If necessary replace filter element with new one.
5. Once per year make a visual check of filter housing and make sure there is no visual damage.
6. The filter has been primarily designed for a life of 10 years in a normal operating environment. For safe operation and respect local law regularly checks the filter according to local regulations.

## 9.2 Service

1. Depressurize the filter and network.

**NOTICE**

**Risk of material damage!**

Using unsuitable tools can lead to damage filter housing or filter elements.

2. Unscrew the nut/bolts and remove filter bowl.
3. Replace the filter element.

**NOTICE**

**Risk of leakage!**

O-ring/gasket can be damaged during the filter element change.

- To prevent leakage and malfunction, check O-ring/gasket before reassembly and replace it if necessary.
  - If a marked degree of damage is found, the entire filter is to be replaced.
4. Check parts for damage, corrosion, damaged O-ring/gasket and replace if necessary.
  5. Lubricate O-ring on the filter element.
  6. Mount the filter bowl on the filter head and screw the nut / bolts, and tighten it.
  7. Carry out a leakage test once the maintenance work has been finished.

**NOTICE**

**Environmental damage in case of faulty disposal!**

The filter element might be contaminated by the filtered substances.

8. Dispose of the used filter element.

## 9.3 Disposing of filter

1. Be mindful of the local regulations.
2. Heed the notes on hazardous substances for the filtered gas and appropriate disposal regulations when disposing.
3. The filter must be rendered useless by sawing.
  - Metallic components can be turned into scrap metal,
  - plastic parts should be recycled,
  - lubricants and other auxiliary materials are subject to provisions regarding the treatment of special waste,
  - dispose of the remaining components after sorting them with respect to the nature of the materials.
4. The type plate should be removed mechanically.
5. Ensure that materials are only disposed of by licensed specialised companies.

### 9.4 Replace the filter element

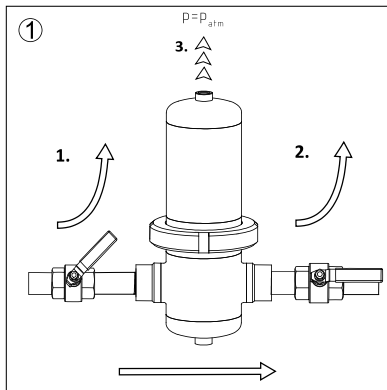

Illustration 13: Depressurize system

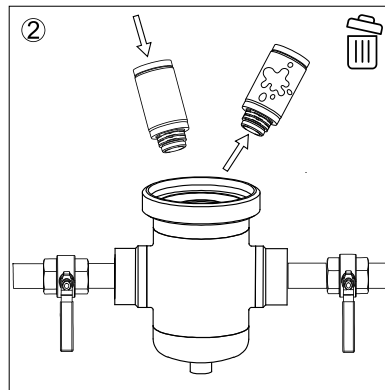

Illustration 14: Replace filter element

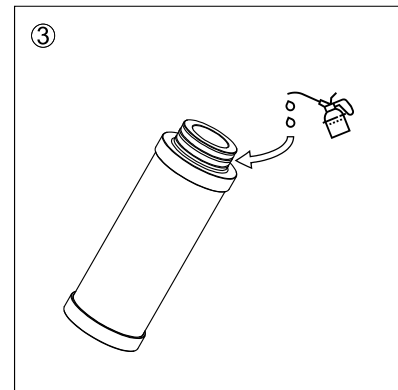

Illustration 15: Lubricate O ring

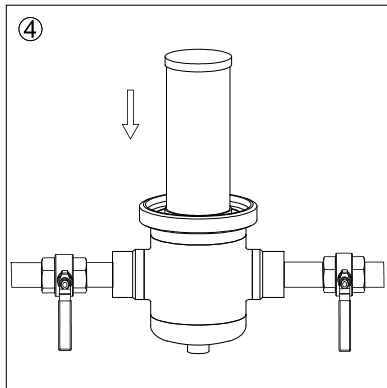

Illustration 16: Insert filter element

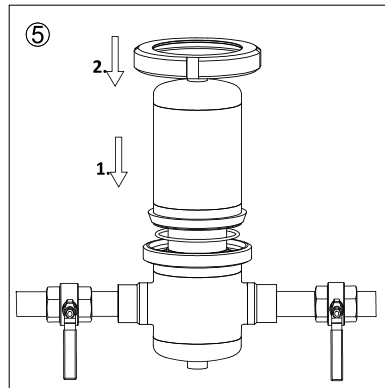

Illustration 17: Mount filter bowl / nut

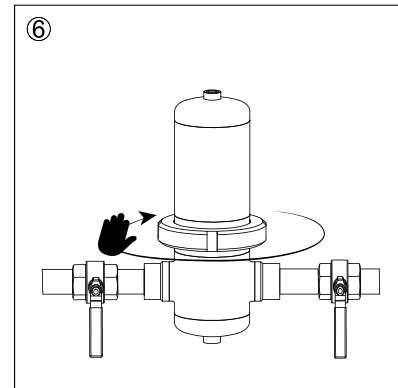

Illustration 18: Tighten nut

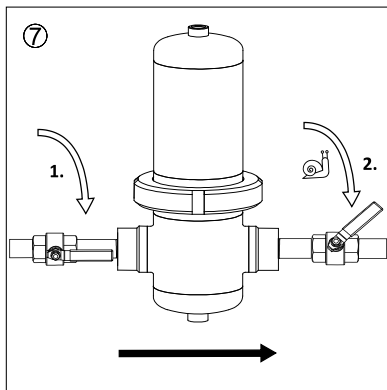

Illustration 19: Open valves

**OMEGA AIR d.o.o. Ljubljana**

Cesta Dolomitskega odreda 10

SI-1000 Ljubljana, Slovenia

Tel.: +386 (0)1 200 68 00

Fax.: +386 (0)1 200 68 50

E-mail: [info@omega-air.si](mailto:info@omega-air.si)

[www.omega-air.si](http://www.omega-air.si)