

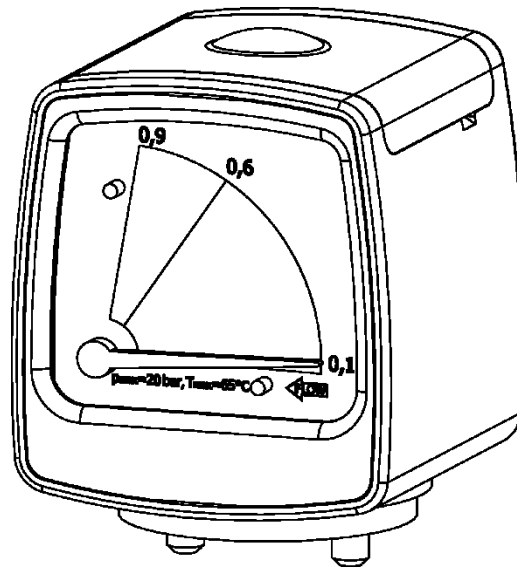

Installation and operating manual

MDM40 / MDM40C



Please read the following instructions carefully before installing electronic drain unit into service. Trouble free and safe operating of the unit can only be guaranteed if recommendations and conditions stated in this manual are respected.

Technical data

Operating temperature	1,5 - 65 °C	35 - 149 °F
Operating pressure (Standard version)	0 - 20 bar(g)	0 - 290 psi
Mass	0,15 kg	0.33 lbs
Indication range	0 - 0,9bar	0 - 13 psi
Indication accuracy	+/- 5% of full scale value	
Typical installation	Head of filter housing	

⁽³⁾ Standard version, at 7 barg

DIMENSIONS

	[mm]	[inch]
A	54	2.12
B	54	2.12
C	64	2.52
D	72	2.83
E	24	0.94
F	40	1.57
G	M5	

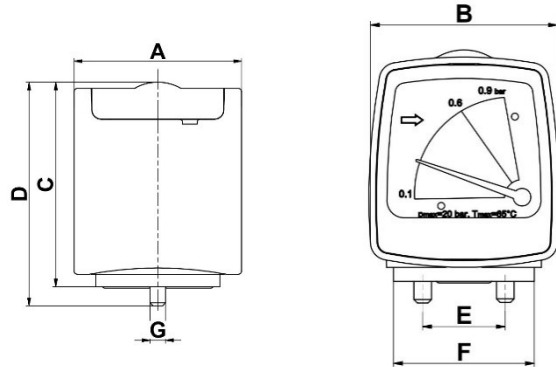

MATERIALS

Housing material	PA6(Polyamide) 30% glass fibres
Housing sealing	NBR
Membrane	NBR
Inspection glass	PC (Polycarbonate)
Mechanism, scale	PA6(Polyamide) 30% glass fibres, ferrite (FeNdB chrome-plated), NBR, stainless steel
Screws	Steel –zinc plated

⁽⁴⁾Standard version

MDM 40C connection specification

Contacts	NO contact/NC contact
Type of contact	Reed
Switching point	0,6 bar
Max. Switching voltage	200 V DC / 140V AC
Max. Switching current	0,5 A AC/DC
Max. Switching power	10 W
Connection	Cable

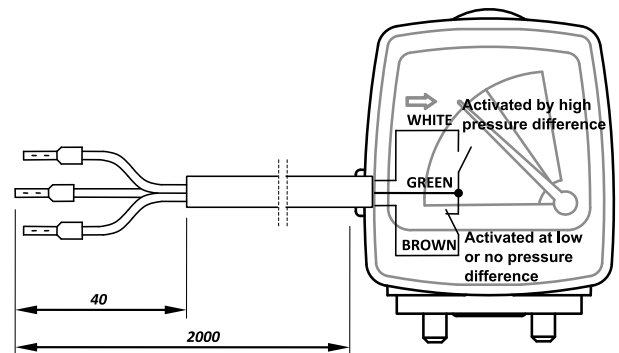

There is Technical datasheet available. For additional technical specification, contact manufacturer.



Safety instructions



Operator/user of the unit should make himself familiar with the function, installation and start-up of the unit through these operating instructions.

It is essential to follow these safety notes in order to ensure trouble-free operation of the unit.

All the safety information is always intended to ensure your personal safety.

- Depressurize the system before carrying out any work on the piping.
- Installation and maintenance work may only be carried out when the device is not under pressure.
-
- Installation and maintenance work may only be carried out by trained and experienced staff.
- Do not exceed max. operating pressure or operating temperature range (see data label).
- Do not use the device in hazardous areas with potentially explosive atmospheres.
- Use original spare parts only.
- Use the device for the appropriate purpose only.

Appropriate use

MDM series manometers are intended exclusively for measuring difference between inlet and outlet pressure of filter.



This appliance must be used only for the purpose for which it was specifically designed. All other uses are to be considered incorrect.

The manufacturer cannot be held responsible for any damage resulting from improper, incorrect or unreasonable use.

Use genuine spare parts only. Any damage or malfunction caused by the use of unguenuine parts is not covered by Warranty or Product Liability.

Installation

- Take MDM 40 from the box and check if there is no external damage visible.
- With plastic screwdriver or prying tool remove the top cover (see figure 1).
- Before you install MDM40 on the filter head, check if two O-rings on the bottom side are in the right position (see figure 2).
- Put MDM40 on filter head. Arrow on the MDM 40 scale indicates flow direction (see figure 3).
- Screw MDM 40 on the filter head with two M5 screws on the top.
- Put the plastic top cover on the MDM 40 and press to lock it in place.



Figure 1



Figure 2



Figure 3

Operating

MDM 40 is magnetic differential manometer. It indicates the difference between inlet and outlet pressure. When the filter cartridge is clogged, the pressure on the inlet is higher than the outlet pressure of the filter. When the pointer reaches red area, filter cartridge is clogged and should be replaced.

MDM40 C – voltage-free contact version indicates clogged filter cartridge remote alarm.

Maintenance

Once per year make a visual check of the pressure drop indicator and make sure there is no visual damage or leakage.

Warranty exclusion

The guarantee shall be void if:

- The operating instructions were not followed with respect to installation, initial commissioning and maintenance.
- The unit was not operated properly and appropriately.
- The unit was operated when it was clearly defective.
- Non-original spare parts or replacement parts were used.
- The unit was not operated within the permissible technical parameters.
- Unauthorised constructional changes were made to the unit or if parts of the unit that may not be opened were dismantled.

OMEGA AIR d.o.o. Ljubljana

Cesta Dolomitskega odreda 10

SI-1000 Ljubljana, Slovenia

Tel.: +386 (0)1 200 68 00

Fax.: +386 (0)1 200 68 50

E-mail: info@omega-air.si

www.omega-air.si

