

BACKGROUND

Compressed air contains contaminants such as water, oil and particulates which must be removed or reduced to the acceptable level based on specific application requirements.

Standard ISO 8573-1 specifies air purity/quality classes for these contaminants. Humidity (water vapour content) is expressed in the terms of Pressure Dew Point (PDP) where Dew point is the temperature at which air is 100% saturated with moisture. When the temperature of the air reduces to or below the dew point, condensation will occur.

Reduction of water content down to pressure dew point +3°C is usually achieved with refrigerant dryers while for lower pressure dew points adsorption (also called desiccant) dryers are typically used.

ADSORPTION

Adsorption is a process where specific molecules adhere to the surface of a highly porous solid (adsorbent/desiccant) by electrostatic and molecular forces. The adsorbent is normally formed in sphere form beads. Process of adsorption takes place while air flows through column filled with the beads.

Rate of adsorption depends on several factors (type of adsorbent, relative humidity, inlet temperature, contact time, face velocity) and therefore adsorption process is usually set/optimized for every individual application.

ADSORPTION DRYER

Typical applications for the adsorption dryers are outdoor installations where the risk of freezing occurs and applications with high quality requirements in terms of air dryness (PDP < +3°C) such as the process air in process industry (food and beverage, pharmaceutical, electronic, chemical, ...).

The most common adsorption dryers are heatless regeneration adsorption dryers due to their simplicity reliability and relatively low investment costs.

CONTROLLER

Adsorption dryer controller ADC 4.0 is the next generation of electronic controllers for compact heatless adsorption dryers. New version brings more functionality to the controller while maintaining simplicity and low cost. In addition to the more advanced electronic the new interface with LCD display, four interface buttons and three indication LEDs give even more interactivity and information to the user.

Controller is suitable for dew point dependent dryer control which can result in significant energy savings.

As an option A-DRY dryers can also be delivered with even more powerful Siemens Logo! Controller.



OMEGA AIR

Air and Gas

A-DRY 6-200

Heatless adsorption compressed air dryers



Floor mounted version



Wall mounted version

Convenient brackets allow the dryer to be firmly mounted on the floor as well as on the wall. Wall mounting is possible simply by rotating the bracket for 90°.

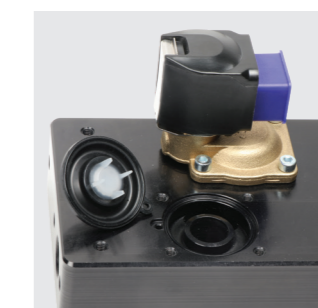

Individually controlled valves

To provide optimum control over the complete drying process four high quality electromagnetic valves are used. Individual control of each valve results in column switch-over without any pressure peaks. Coils are spring fixed which assures stable operation even under most difficult conditions (e.g. portable applications, railway, heavy vibrations, ...)



Heavy duty valve design

Design of the membrane is optimised for pressure swing adsorption applications.

Plastic reinforcement & guiding plate increases lifetime of the membrane and assures reliable operation.



Compact control blocks

Due to compact design of upper and lower control block check valves and purge air nozzles are integrated in the robust block which results in a reliable operation and easy replacement during service procedure. Additionally valves are protected by a sheet metal plate.



Manometers

Two manometers positioned on top of the upper control block give reliable information about the pressure inside of each column. In combination with LED indication on the controller manometers are excellent tool for diagnostics.



High quality two layer desiccant bed

A-DRY series adsorption dryers are filled with a high quality robust desiccant which results in a stable operation with a low energy input for the regeneration. Primary desiccant is a molecular sieve with an extremely high drying potential. To prevent potential degradation of primary desiccant due to liquid water, bottom part of the column is filled with a water resistant silica gel.



Spring fixed desiccant bed

Movement of the desiccant causes abrasion and channeling which results in decrease of the drying efficiency. Therefore every A-DRY column is equipped with a spring which provides constant force on the desiccant bed thus assuring uniform distribution of beads without any movement during operation.



Integrated exhaust silencers

Each column contains integrated exhaust silencer for efficient noise reduction due to compressed air pressure release during column switch over process.

Exhaust silencers provide low released compressed air velocities and safe working environment.



Removable desiccant column

Only two screws are necessary to release the desiccant column. Replacement of the desiccant media has never been so quick and easy - you save your valuable time and money.

The columns and the cover sheet metal parts are epoxy powder painted while all the other aluminium parts are anodized to prevent any potential oxidation.

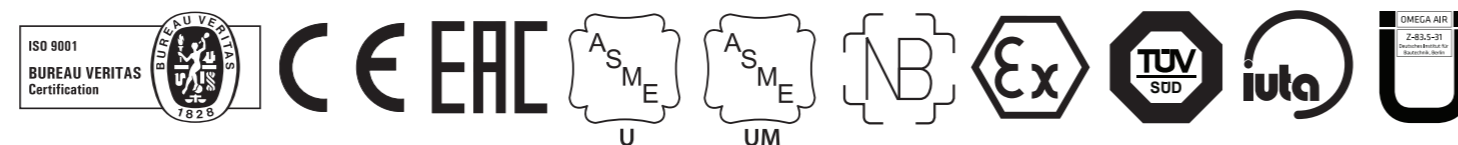

OMEGA AIR d.o.o. Ljubljana

T +386 (0)1 200 68 00

info@omega-air.si

Cesta Dolomitskega odreda 10
SI-1000 Ljubljana, Slovenia
www.omega-air.si

950370 - 10/2020



Components

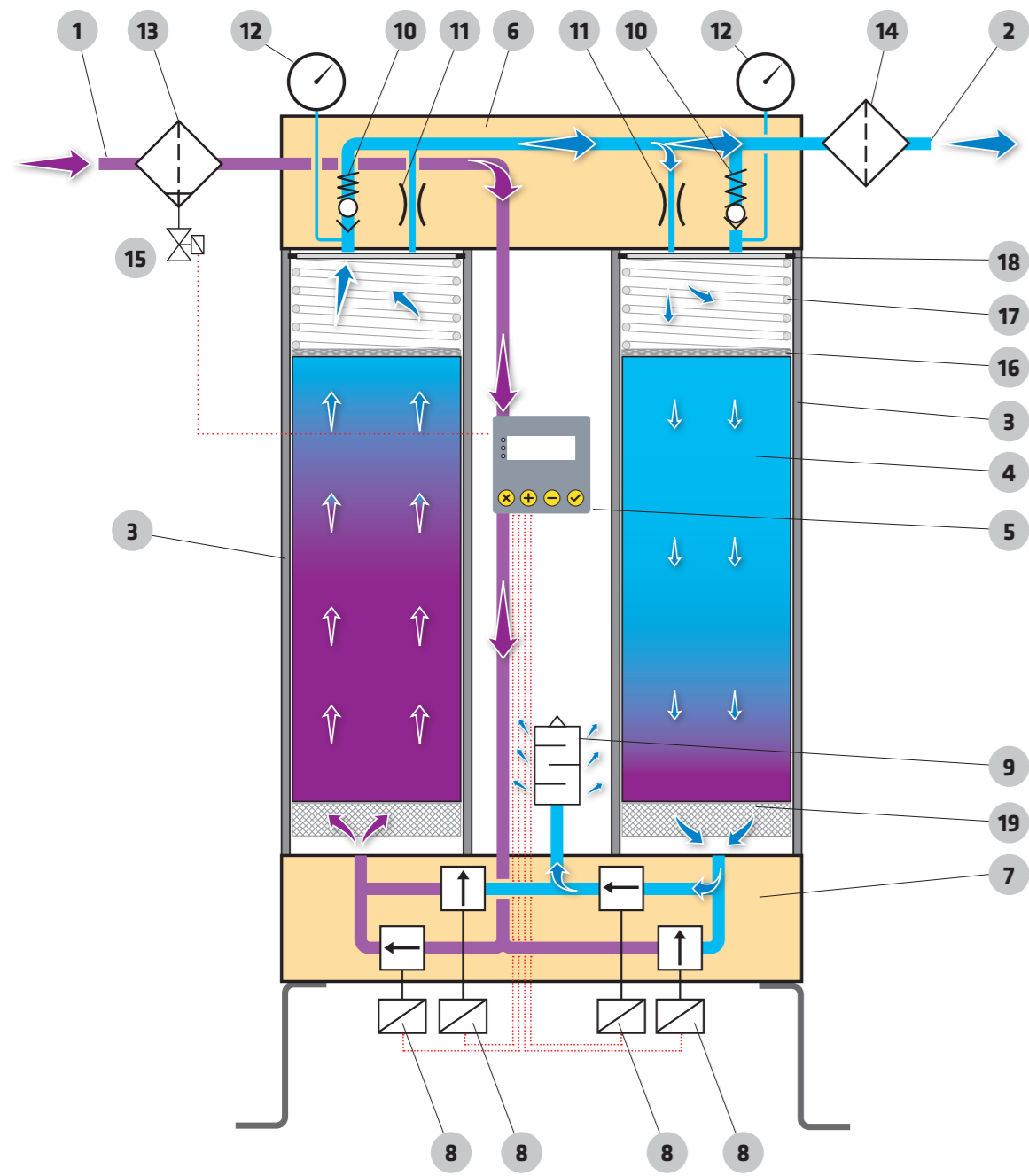

A-DRY adsorption dryers have been designed for continuous separation of water vapour from the compressed air thus reducing the pressure dew point.

Compact A-DRY series dryer consists of upper and lower control block, controller with LED display and two alternately operated columns filled with desiccant. Adsorption takes place under pressure in the first column while the

second column regenerates with a portion of already dried compressed air at ambient pressure.

When the first column is saturated to a certain level column switch-over is carried out and the process of adsorption continues in the second column without any drop of pressure at the outlet of the dryer. Regeneration of saturated desiccant is

possible because a small portion of already dry compressed air is decompressed and when expanded it becomes extremely dry.

This portion of extremely dry decompressed air also called "purge air" is then fed through the saturated column in the reverse flow direction in order to remove the adsorbed water molecules from the desiccant and release them back to the ambient.

Operating cycles

A-DRY dryers can operate in two operating modes based on setting of the controller.

Fixed cycle mode

Switch over between columns is timer controlled. Due to high quality adsorbent and advanced control method adsorption cycle is extended to 10 minutes resulting in lower amount of switch overs thus lower consumption of compressed air and less wear of vital components.

Adsorption = 5 min
Regeneration = 4 min
Pressure build up = 1 min

ENERGY SAVING

Variable cycle mode

(Dew point dependent switch over)

If dew point sensor is connected to the controller duration of adsorption can be extended based on reading of the sensor while regeneration is still carried out in just 4 minutes.

Operating dryer in variable cycle mode can result reducing average purge air consumption to an extremely low values (even below 3%).

ENERGY SAVING

Stand-by mode

A-DRY series adsorption dryers have an option to receive a stand-by signal from the compressor or other compressed air supply. While in the stand-by the air can flow freely through both towers in direction from the inlet to the outlet of the adsorption dryer.

Meanwhile the adsorption dryer controller is in the stand-by mode and ready to resume with the normal operation as soon as it gets the appropriate signal. The stand-by signal is relayed to the A-DRY adsorption dryer through a stand-by contact on the controller by a connected switch.

- 1 Compressed air inlet (wet air)
- 2 Compressed air outlet (dry air)
- 3 Column filled with desiccant
- 4 Two layer desiccant bed
- 5 Controller
- 6 Upper control block
- 7 Lower control block
- 8 Solenoid valve
- 9 Air silencer
- 10 Non-return valve
- 11 Nozzle
- 12 Pressure manometer
- 13 Inlet air filter
- 14 Outlet air filter
- 15 Condensate drain
- 16 Stainless steel mesh
- 17 Spring
- 18 Safety ring
- 19 Stainless steel mesh

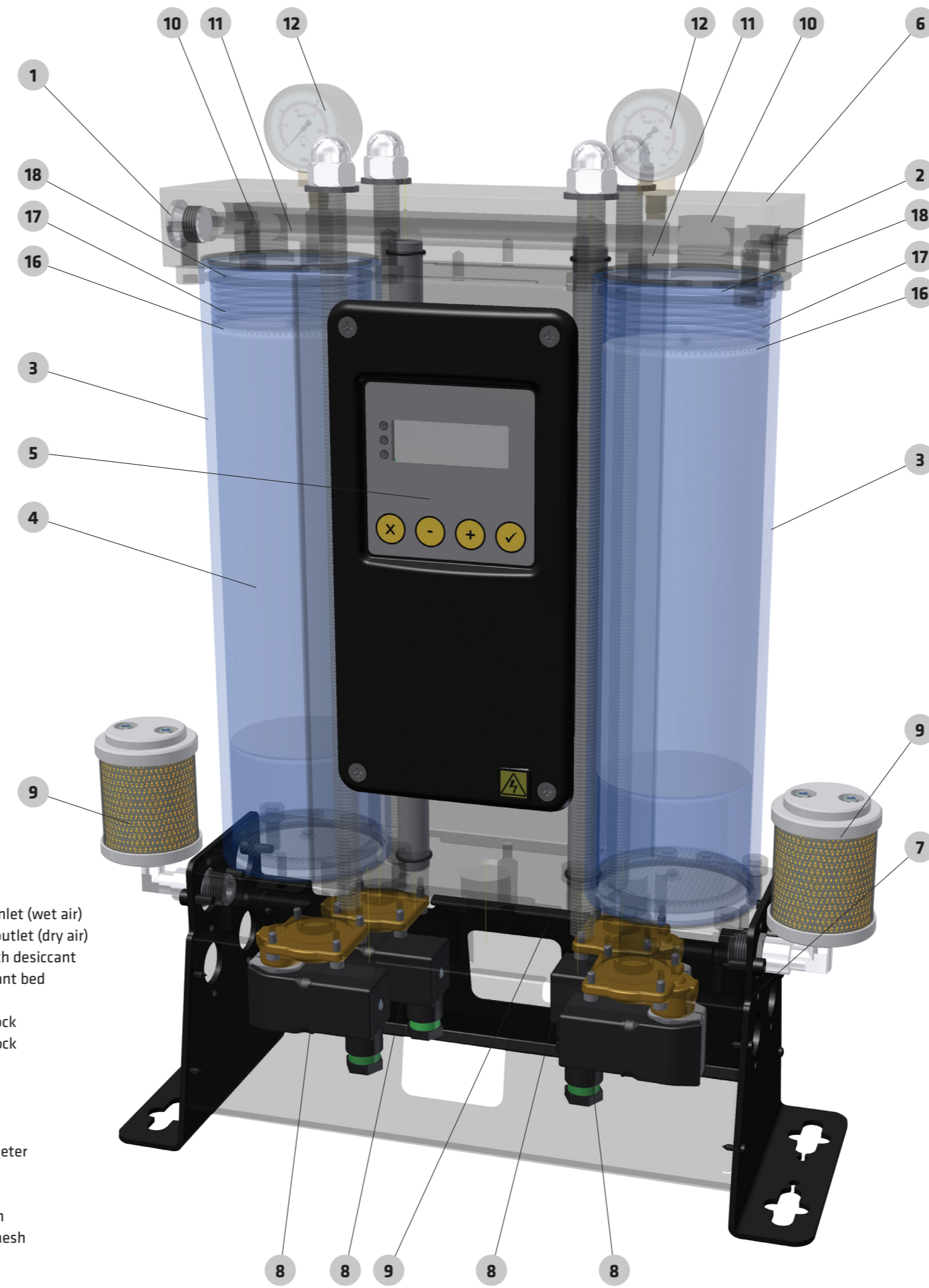

Easy maintenance

Due to innovative column design desiccant replacement can be done in a few minutes.

Complete column can be removed from the dryer just by releasing four top nuts and by removing side locking screws. Column can then be refilled or completely replaced with a new one.

When the column is removed clear access to the check valve and the purge nozzle is available without the need to dismantle complete adsorption dryer.

Valves and membranes are located underneath the lower control block and can be accessed and replaced in a quick and easy way.



- 1 To remove column unscrew two side locking screws (one from the upper and one from the lower control block).
- 2 Unscrew the four locking nuts from the upper control block.
- 3 Remove the column and replace the desiccant bed.

Technical data

Type	Connection IN/OUT	Nominal volume flow		Dimensions							Mass kg	Vessel volume (l)	Filter
		Inlet ¹⁾	Outlet ²⁾	A [mm]	A* [mm]	B [mm]	B* [mm]	C [mm]	C* [mm]	D [mm]			
		[Nm ³ /h]	[Nm ³ /h]										
A-DRY 06	G 3/8"	6	4,7	339	520	280	480	100	130	354	10,5	1,30	AF 0056
A-DRY 12	G 3/8"	12	9,5	573	715	280	480	100	130	354	13,5	2,17	AF 0056
A-DRY 24	G 3/8"	24	19,0	1.041	1.105	280	480	100	130	354	19,0	3,89	AF 0056
A-DRY 36	G 3/8"	36	28,4	1.364	1.495	280	480	100	130	354	27,5	5,61	AF 0056
A-DRY 60	G 3/4"	60	47,4	972	1.105	370	570	148	170	434	45,0	9,95	AF 0076
A-DRY 75	G 3/4"	75	59,3	1.167	1.300	370	570	148	170	434	53,0	12,2	AF 0076
A-DRY 105	G 3/4"	105	83,0	1.567	1.700	370	570	148	170	434	70,0	16,6	AF 0106
A-DRY 150	G 1"	150	118,5	1.345	1.440	440	725	198	240	570	170,5	26,3	AF 0186
A-DRY 200	G 1"	200	158,0	1.538	1.655	440	725	198	240	570	182,2	31,2	AF 0186

Operating pressure range	4 to 16 bar(g)
Operating temperature range	+1,5 °C to +50 °C
Pressure dew points	-40 °C (-25 °C, -70 °C)
Voltage, frequency	230 V, 50/60 Hz
Power consumption	<35 W
Protection class	IP 65
Filter (inlet)*	super fine coalescing ; 0,01 µm
Filter (outlet)	dust filter; 1 µm

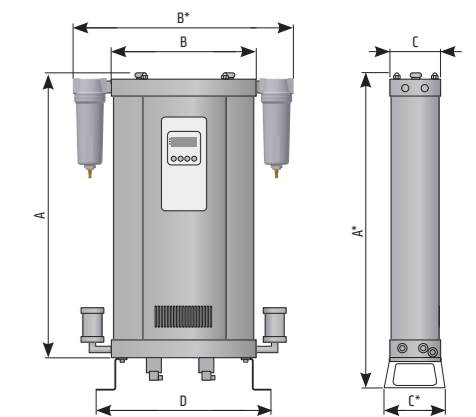

¹⁾ Refers to 1 bar(a) and 20 °C at 7 bar operating pressure, inlet temperature 35 °C and pressure dew point at outlet -40 °C.
²⁾ Outlet flow refers to typical assumption during regeneration phase for operating at nominal inlet flow conditions. Outlet flow includes average air losses of approximately 17,3 %.
* If dryer is supplied without inlet filter compressed air class 1 (ISO 8753-1) for solid particles and oil should be provided to the inlet of the dryer.

CORRECTION FACTORS - F1																
Operating pressure [bar]	4	5	6	7	8	9	10	11	12	13	14	15	16			
Operating pressure [psi]	58	72	87	100	115	130	145	160	174	189	203	218	232			
Correction factor	0,63	0,75	0,88	1	1,13	1,25	1,38	1,50	1,63	1,75	1,88	2,00	2,13			

CORRECTION FACTORS - F2						DEW POINT				
Inlet temperature [°C]	25	30	35	40	45	50	[°C]	-25	-40	-70
Correction factor	1,00	1,00	1,00	0,97	0,87	0,80	C _p	1,1	1	0,7